

MAXIMATOR®

Operating instructions

Disc filters 1500 bar, 4500 bar / 1/4", 3/8", 9/16"

1. Safety advice:

Operation and installation of the component parts may only be performed by trained persons. The statutory provisions of the German Employers' Liability Insurance Association (BG) and other institutions must be complied with. In addition, these Operating Instructions have to be studied thoroughly and fully adhered to.

2. Method of functioning / Use:

MAXIMATOR® Filters collect solid matter particles from passed through fluids and gases. The filters must not be subjected to any modifications (e.g.: mechanical alterations, welding, soldering, etc.). The maximum filter differential pressure is 10 bar. The characteristic filter curves indicate maximum throughput rates. Please, not that the differential pressure rises with increasing soling. Hence, replace filter cartridges in good time.

3. Technical information:

Media: Only media included in our media endurance list may be used. All other media have to be checked by us for their compatibility with valve materials prior to use. In addition, the respective statutory provisions must be absolutely complied with when inflammable, explosive or toxic substances are used.

Type of load: MAXIMATOR® Filters are designed for static loads. Life expectancy of the filters is reduced under dynamic load conditions.

Media temperature: -50 °C +350 °C
Max. pressure drops with rising temperature. (confer P/T diagram)

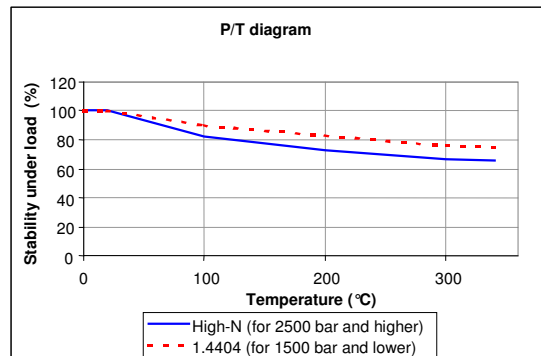

4. Assembly:

Make sure to observe direction of flow during assembly.

HP pipe:

1. Push thrust bolt over the HP pipe.
2. Screw on thrust collar till to end of thread and turn back by one turn (left-handed thread). Make sure that 1-2 threads are free between sealing cone and thrust collar.
3. Screw thrust bolt into the valve body connecting bore and tighten with tightening moment as indicated in the below table.

Tightening moment for thrust bolts:

Pressure connection	Pipe connection dimensions	∅D	Thrust bolt Width across flats (SW)	Tightening moment
bar	inches	mm	SW in mm	Nm
1500	1/4"	6.35	SW 13	30
	3/8"	9.53	SW 17	40
	9/16"	14.3	SW 24	75
4500	1/4"	6.35	SW 17	35
	3/8"	9.53	SW 22	70
	9/16"	14.3	SW 32	150

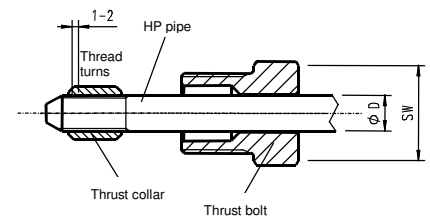

Remark: Prior to assembly (and if the medium permits such) all threads and sealing cones should be treated with a suitable lubricant (e.g. copper paste)!

MAXIMATOR® GmbH

37449 Zorge, Walkenrieder Str. 15, Tel.: ++49 (0) 5586 803 0, Fax: ++49 (0) 5586 803 40

e-mail: info@maximator.de, website: www.maximator.de

5. Dismantling:

Dismantling is performed in reverse order as assembly.

Remark: Make sure that the system is depressurised before start of dismantling!

6. Maintenance:

MAXIMATOR® Filters are maintenance-free! Replace filter elements when soiled. Appropriate intervals for periodic replacement of filter elements to be decided by the filter operator.

7. Servicing / Repair:

Any servicing work may only be performed by trained persons.

Dismantle the filter as described under item 5. above before removal of filter elements.

Removal of filter element

1. Loosen thrust bolts and take out together with plug.
2. Press used-up filter elements out of the filter body with a plastic mandrel.
3. Put the filter body over the caulking anvil. Flow to the caulking anvil.
4. First, place the finer filter element into the filter body and caulk it with a caulking mandrel and several hammer strokes.
5. Check filter tightness by means of a lamp. If a light gap is found, apply higher pressure to the filter element.
6. Insert spacer disk into the filter body.
7. Insert and caulk the coarser filter disc.
8. Re-insert plug and screw down thrust bolts. [200 Nm at 9/16" 1500 and 4500 bar; 150 Nm at 1/4" and 3/8" 4500 bar]

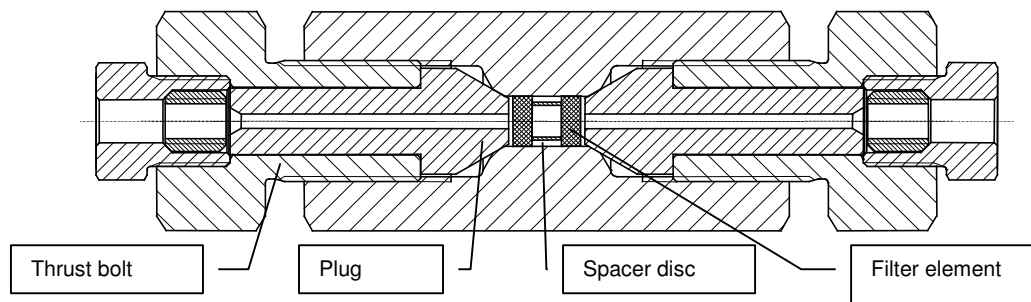

Malfunctions:

Malfunction	Possible cause	Remedy
Medium escapes via relief bore at pressure connections	Faulty assembly of pressure connection Cone surface is damaged	Check for proper assembly Re-machine cone surface with a seat reaming tool

All component parts of filters can be obtained from us as spares. Please, indicate in your spare part order the respective serial number, item number and valve type, provided on the disc filter body. We also offer repair services in our workshop, performed by our qualified service technicians.

8. Warranty:

We grant for MAXIMATOR® Filters a warranty of twelve (12) months on material quality and workmanship, commencing with the filter shipment date. Any deficiencies that are due to improper handling, use of inadmissible media or exceeding of maximum operating pressures are not subject to our warranty obligation. Wear parts, e.g. filter elements, are exempted from warranty.

9. Disposal:

Filters are to be disposed of in compliance with national regulations upon the end of their useful lives.